

IKDV01 Keypad Push Button System

IEC Ex 07.0018X [Ex ia] I

1. Description

The Ampcontrol IKDV01 Keypad Push Button System is used in conjunction with the Ampcontrol range of Integrated Protection Relays. The Keypad is approved to Ex ia Intrinsic Safety Standards so that it can be installed outside the flameproof enclosure.

The use of the IS Keypad System eliminates the conventional flameproof buttons normally used on a Distribution Control Box (DCB).

A faulty keypad can be changed out at the face, whereas a damaged flameproof actuator requires the DCB to be removed from service for repairs.



3.1 Standard Mode of Operation (Mode 1)

To set the Interface for Standard operation set DIP Switch 2 **OFF** and Dip Switch 3 **ON**. The switches are located on the IKDV01 Interface Module.

Push Buttons provide the following eight functions when the interface is connected to an Integrated Protection Relay:

- Stop
- Start
- Lock (To enable the Integrated protection Relay to be programmed)
- Reset
- E/C Test (Earth Continuity Test)
- EFLO Test (Earth Fault Lockout Test). Used in conjunction with Earth Fault Test Modules)
- E/L Test (Earth Leakage Test). Selection of DIP Switch 4 provides 150 or 600 ms delays for test purposes. E/L Test Relay is connected to 110 VAC supply. Can be used as an injection source
- RL1 (Operates internal relay RL1, which closes an output contact)

3.2 PLC Control (Mode 2)

To set the Interface for PLC Control set DIP Switch 2 **ON** and DIP Switch 3 **OFF**. The switches are located on the IKDV01 Interface Module.

When the IKDV01 Interface Module has been set to Mode 2 the Programmable Logic Controller controls the outlet of the DCB. The main difference to the Standard Operation is as follows:

1. No stop reset is required on power up
2. Operation of the Start key causes RL1 output to close (while key is closed)
3. Operation of RL1 Key has no action
4. Start opto-output is disabled

See IKDV01 User Manual for full details.

CAUTION!



The user is responsible for assisting in the maintenance of the Ex ia Intrinsic Safety rating by complying with the "Conditions of safe use" outlined in the certificate.

The keypad module consist of eight push button keys, each fitted with acknowledge LEDs and associated electronics.

The keypad module is connected to the IKDV01 Interface Module by a three-wire cable. The keypad module receives power and communicates with the IKDV01 Interface via this cable. The setting of DIP Switches 2 and 3 will configure the Interface Module for Standard Operation or PLC Control.

When a keypad key is operated the corresponding relay or opto-isolated output in the IKDV01 Interface Module responds and activates its output.

2. Features

- Intrinsically Safe. Allows push buttons to be installed outside the flameproof enclosure.
- Opto-isolated outputs
- Watch dog timer continually checks stop circuit
- Compact design
- Easy on site replacement
- Provides Earth Leakage, Earth Fault Lockout and Earth Continuity tests
- Standard Operation and PLC Control

3. Application

When power is applied to the IKDV01 Interface Module, the outputs remain off until communications with the keypad is healthy and the Stop key has been pressed (only applies when Mode 1 is selected).

When power is first applied to the keypad (via the IKDV01 Interface) all LEDs on the push button keys will flash simultaneously until communication is established. This flashing may continue if wiring to the keypad is faulty or the Interface Module itself is faulty.

3.2.1 Operation (PLC)

RL1 relay output contact is connected to a PLC Input.

A PLC Output is connected to the start input on the Integrated Protection Relay.

Operation of the Start push key operates an internal relay RL1 in the IKDV01 Interface Module. This relay output closes the PLC input. Depending on the user's PLC code, the PLC may be used to initiate any pre-start procedures, such as the operation of warning alarms etc.

At the successful conclusion of any pre-start routines, the PLC output should be closed which will operate the Integrated Protection Relay that energises the outlet.

All other key operations for Test, Reset, Lock and Stop are the same as described for Standard Mode of Operation (Section 3.1).

4. Specifications

Supply Volts

110 Vac \pm 20%, 50 Hz \pm 2 Hz

Mode of Operation Settings:

Mode 1 – Standard Operation

Dip Switch 2 OFF

Dip Switch 3 ON

Mode 2 – PLC Control

Dip Switch 2 ON

Dip Switch 3 OFF

Earth Leakage Time Settings:

Dip Switch 4 ON – 500 ms

Dip Switch 4 OFF – 150 ms

Relay Contacts:

RL1, E/L, Test and Stop

1N/O 5A/ 190 VAC 100 VA maximum

5 Parts List

110142	IKDV01 Interface
110143	Standard IS Keypad
117439	Earth Fault Test Module-415 V
101493	Earth Fault Test Module – 1 kV
117440	Earth Fault Test Module - 3.3 kV
110910	IKDV01 User Manual

IKD Block Diagram

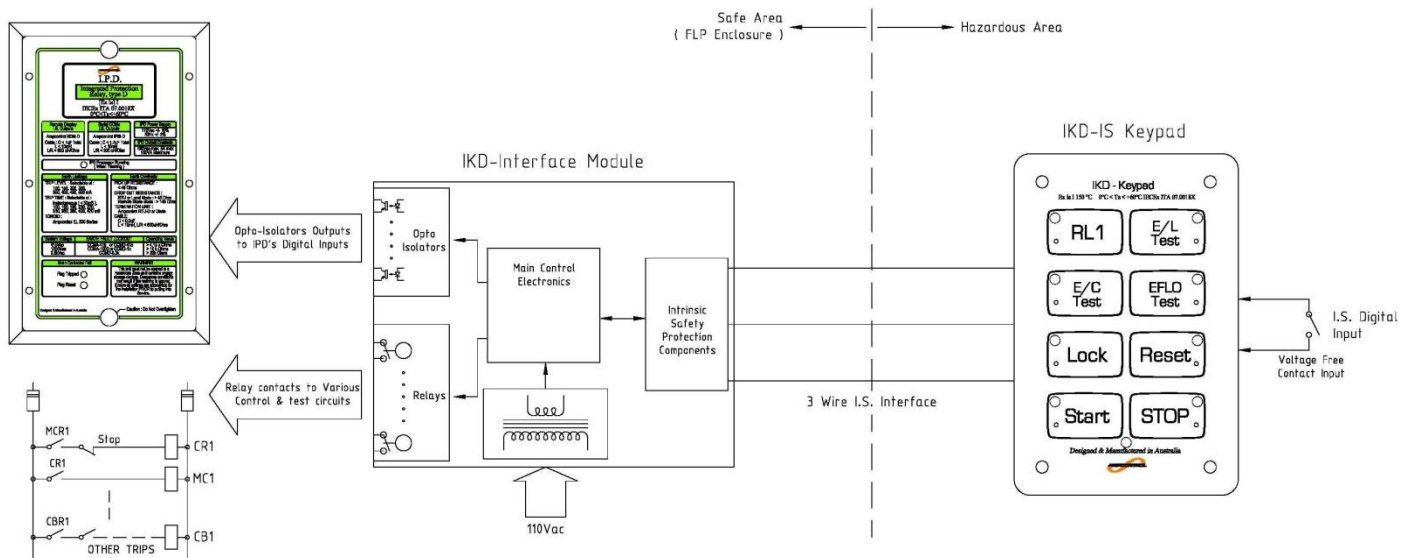

AMPCONTROL ELECTRONICS

Amppcontrol CSM Pty Ltd ABN 35 000 770 141
7 Billbrooke Close CAMERON PARK NSW 2285

Phone: (02) 4903 4800

Fax: (02) 4903 4888

E-mail: electronicsorders@ampcontrolgroup.com

Web site: www.ampcontrolgroup.com

