

Diesel Machine Monitor

ANZ Ex 05.4010X Exm [ia] I

Description

The Dieselguard Machine Monitor provides the key functionality of signal monitoring and control as part of Ampcontrol's diesel machine monitoring systems. The Diesel Machine Monitor includes all necessary signal inputs, outputs and power supplies required by the sensors, switches and alarms that comprise a machine based monitoring system.

Dieselguard provides in-built control functions to facilitate safe operation of diesel machines by allowing engine start-up only when explosive gas concentrations are below safe limits, and engine shut down if concentrations reach or exceed those limits.

Dieselguard can also be programmed to shut down a machine if exhaust temperature or engine rpm exceeds safe working limits. A configurable auxiliary analogue input provides a means to monitor additional machine parameters such as oil pressure.

Dieselguard provides continuous time-stamped data logging of all gas, temperature, rpm and auxiliary sensor input readings as well as alarm status, battery charge condition and machine engine-run hours.

An in-built wireless interface provides a means to retrieve the logged data for those systems supplied with wireless functionality.

Advanced versions of Dieselguard can be user-configured via the wireless link using an optional wireless base station and PC based configuration tool.

Dieselguard comprises a rugged 316 stainless steel IP66 low profile enclosure housing encapsulated electronics and I.S. field terminations for external sensors, displays and alarms.

All electrical field connections to Dieselguard have defined IS entity parameters, allowing flexible connection to compatible devices such as gas transmitters, RTD's, pressure and level switches, LED indicators, solenoid valves and IS display systems.

Features

- Provides all controls functions required for machine to start-up and shut-down.
- Gas, temperature and rpm sensor inputs.
- Switch inputs for start, reset and deputy override.
- Shut down on gas, temperature or engine rpm levels.
- Warn and shutdown alarm levels available for all sensor inputs.
- Latching trip function.
- Can drive multi-colour LED display unit or LED alarm beacons.
- IP66 sealed enclosure with security screws.
- Vehicle ID selection.
- Engine hours run logging.
- PC software for long retrieval and configuration (wireless logging versions only).
- IS entity parameters for all field connections.



Specifications

Power input	AC/ DC 9-36V
Consumption (whole system)	400mA / 1.0A with battery on full charge rate.
Temperature Range	-20 to 60C
Operation Time (No charge input)	2-3 hrs (in 2 min time sections) (40-60 start sequences)
Cabinet sealing	IP 66
Certification	ANZ Ex 05.4010X Exm [ia] I
Gland entries	9 x 16 mm diameter
Case material	1.6mm 316 Stainless Steel
Mounting holes	4 off 8mm OD
Case size	320mm x 200mm x 85mm
Weight	8.5 kg
Gas Sensor input	4-20mA
Aux Analogue	0-2.5V
RPM	0-15kHz
Alarm Levels	Preset 1.00% and 1.25 % CH4. Adjustable by radio link for other applications.
RTD inputs	2 x two wire type. 1 x 4 wire
Digital input (system reset/start)	Monitored contact (IS circuit)
Deputy Key Input	Monitored contact (IS circuit)

On Board Data Logging

The following information can be logged:

- Vehicle ID
- Engine hours run
- Temperature for three RTD inputs
- Gas levels
- Real time clock
- Deputy over-ride selected
- Battery charge level
- Digital input
- Analogue input
- Proximity input

These logged features are able to be downloaded by a 2.4GHz radio link when the vehicle is within a 50m range of the receiving station (stationary).

The logging function logs data every 2 minutes unless the unit is in a warning or tripped state where it will log every 4 seconds.

The logging capacity is sufficient to hold over one week's data in normal operation (seven 8 hour shifts continually running) in continuous use, or approximately 4 hours of alarm data. Logging Only takes place while the engine is running or in the two minute period during start up or power down.

Associated Equipment

Gasguard CH4 gas sensor / transmitter, MDA and IS approved in a robust Stainless Steel enclosure. Part No. 106198.

Optional remote sensor head gas detectors are available. Contact Ampcontrol Cameron Park to request data sheet GSB001.

IDA 3 digit LED tri-colour display. IS approved design in robust stainless steel enclosure. Part No. 101706. Contact Ampcontrol Cameron Park to request data sheet IDAB001.

Asco WPIS314 IS solenoid valve. 3 way with 1/4 NPT ports and 1/8 NPT vent.

Gas sensor calibration kit 121047.

Equipment List

- | | |
|--------|--------------------------------------|
| 106908 | Dieselguard Machine Monitor |
| 106198 | CH4 Gas Detector |
| 105239 | Dieselguard Base Station RF Receiver |
| 121425 | Dieselguard User Manual |
| 101706 | Intrinsically Safe Display |

Diesel Machine Gas Detection System

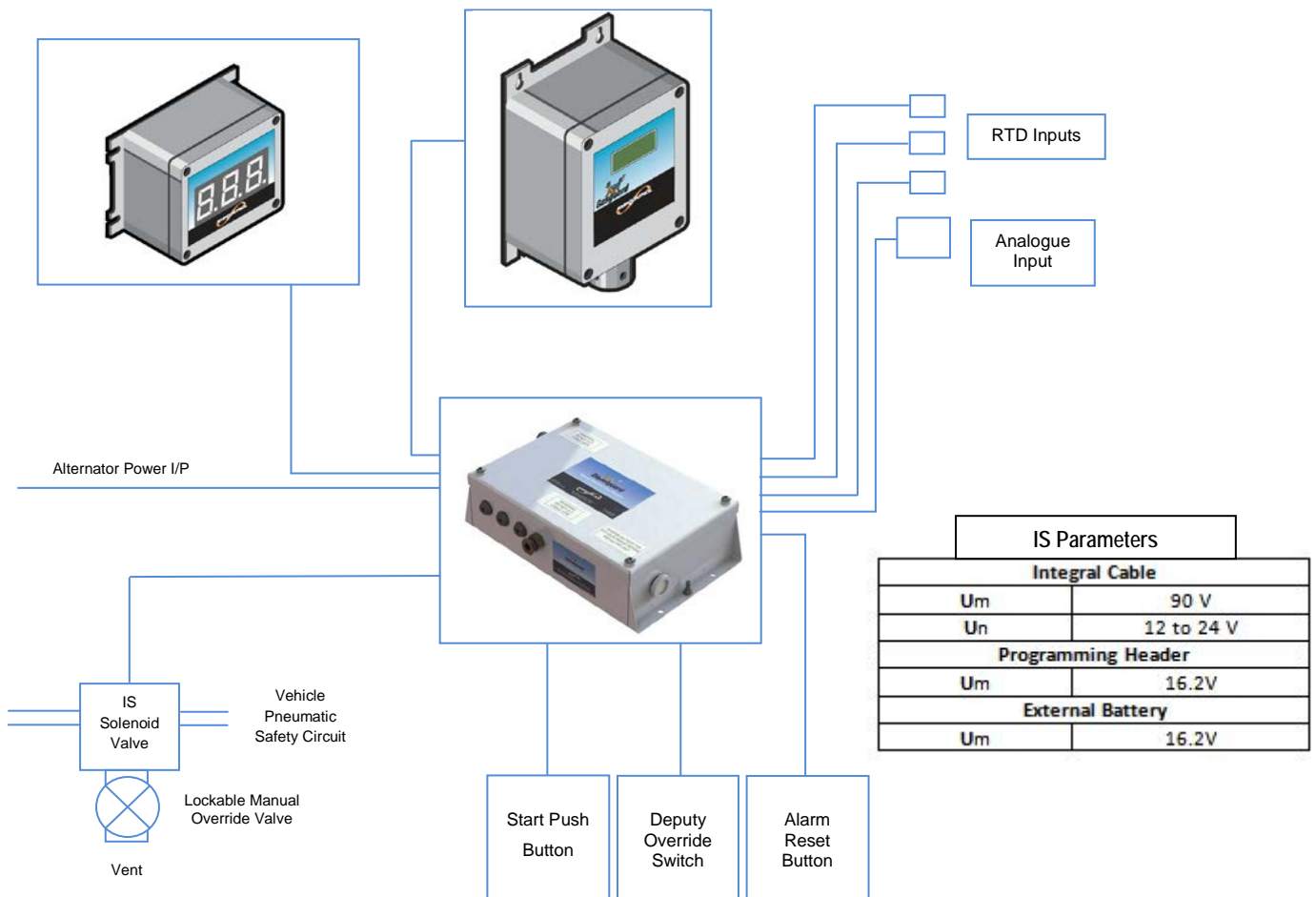

AMPCONTROL ELECTRONICS

Ampcontrol CSM Pty Ltd
 ABN 35 000 770 141
 7 Billbrooke Close CAMERON PARK NSW 2285
 Phone: (02) 4903 4800
 Fax: (02) 4903 4888
 E-mail: electronics@ampcontrolgroup.com
 Web site: www.ampcontrolgroup.com

